

NOTES: MATERIAL & FINISH
 1.INSULATOR:HIGH-TEMP THERMOPLASTIC, UL94V-0
 COLOR:BLACK
 △△2.CONTACT:PHOSPHOR BRONZE ;t=0.25△
 PLATING:TIN OR MATTE-TIN PLATED
 3.PIN No.1 MEANS POSITION OF THE FIRST PIN OF FPC.
 4.ORDER INFORMATION: 7101K-X XX N-00X

PACKING: E: TUBE
 C: TRAY

STANDARD
 PIN
 △PLATING: E: TIN
 Q: MATTE-TIN

△△ 7101K:1.0 NON/ZIF FPC DIP R/A TYPE
 (Halogen Free)

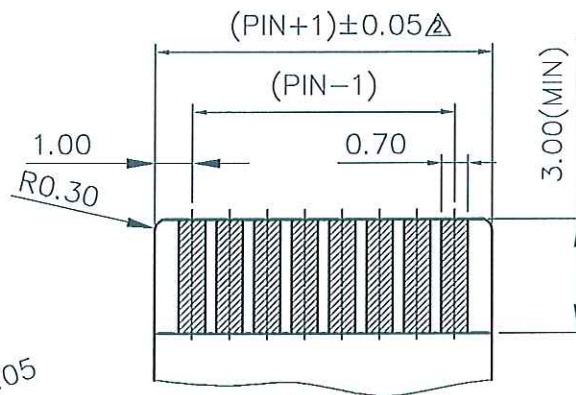
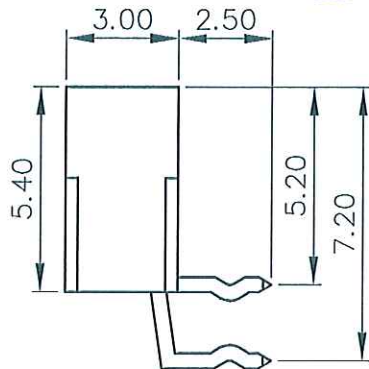
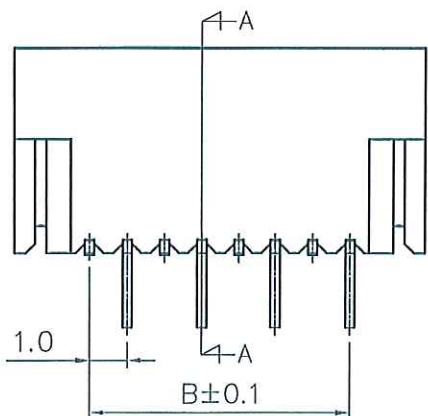

RECOMMENDED APPLICABLE
 FPC LAYOUT (THICKNESS: 0.3±0.03)

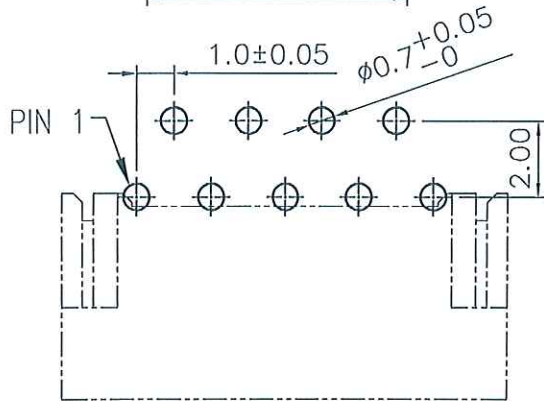

RECOMMENDED PATTERN DIM.
 FOR OOD CKT. (REF.)

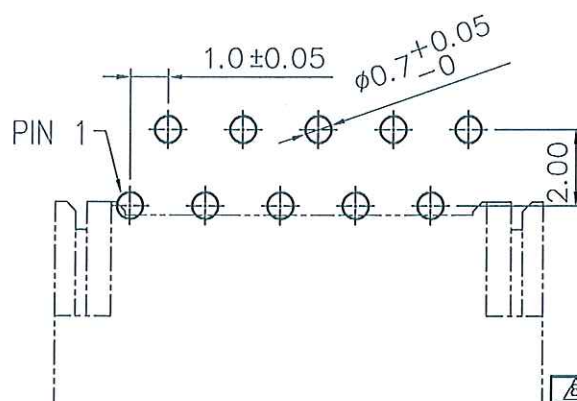

RECOMMENDED PATTERN DIM.
 FOR EVEN CKT. (REF.)

PIN	A	B	C
03	6.0	2.0	4.15
04	7.0	3.0	5.15
05	8.0	4.0	6.15
06	9.0	5.0	7.15
07	10.0	6.0	8.15
08	11.0	7.0	9.15
09	12.0	8.0	10.15
10	13.0	9.0	11.15
11	14.0	10.0	12.15
12	15.0	11.0	13.15
13	16.0	12.0	14.15
14	17.0	13.0	15.15
15	18.0	14.0	16.15
16	19.0	15.0	17.15
17	20.0	16.0	18.15
18	21.0	17.0	19.15
19	22.0	18.0	20.15
20	23.0	19.0	21.15
21	24.0	20.0	22.15
22	25.0	21.0	23.15
23	26.0	22.0	24.15
24	27.0	23.0	25.15
25	28.0	24.0	26.15
26	29.0	25.0	27.15
27	30.0	26.0	28.15
28	31.0	27.0	29.15
29	32.0	28.0	30.15
30	33.0	29.0	31.15
31	34.0	30.0	32.15
32	35.0	31.0	33.15

ENTERY INDUSTRIAL CO., LTD
 JAN 1 0. 2013
 R&D D.C.C. ISSUED

SER	REVISIONS	CHK	DATE
△	RE201206014	JIMMY	12/21/12
△	REN101225	Joan	12/15/10
△	REN101221	JIMMY	12/13/10
△	REN90822	Hunter	08/25/09
△	REN80503	Joan	05/07/08
△	RE080206	Joan	03/13/08

CUSTOMER

恩得利工業股份有限公司
 E & T
 ENTERY INDUSTRIAL CO., LTD.

DRAWN
 Josh OCT-08-2004
 CHECKED
 APPROVED
 SHEET

PART NO. △
 △ 7101K-XXXN-00X
 TITLE:
 1.0 NON/ZIF FPC
 DIP R/A TYPE
 UNIT MM SCALE 5:1 SIZE A4 REV I