

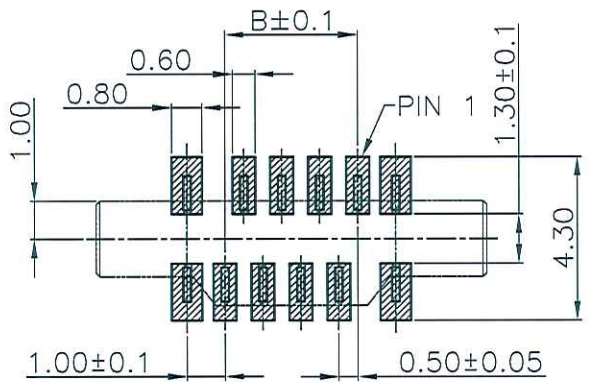

NOTES: MATERIAL & FINISH
 1. HOUSING: HIGH-TEMPERATURE THERMOPLASTIC UL94V-0
 COLOR: BLACK
 2. ACTUATOR: HIGH-TEMPERATURE THERMOPLASTIC UL94V-0
 COLOR: WHITE
 3. CONTACT: COPPER ALLOY, t=0.2mm
 PLATING: TIN OR MATTE-TIN OR GOLD FLASH
 OR CONTACT AREA NICKEL, SOLDER AREA TIN PLATED
 4. FITTING NAIL: COPPER ALLOY, t=0.2mm
 PLATING: TIN PLATED
 5. ORDER INFORMATION: 6700K-X XX X-06X

PACKING: E: TUBE
 R: PLASTIC REEL
 L: PAPER REEL
 S: WITH CAP
 N: WITHOUT CAP
 PIN
 PLATING: E: TIN
 Q: MATTE-TIN
 F: GOLD FLASH
 Y: GOLD FLASH (WITH NICKEL BARRIER)
 J: CONTACT 10u"(MIN) GOLD
 H: CONTACT 15u"(MIN) GOLD

6700K: 0.5 ZIF FPC SMT V/T (HALOGEN FREE)

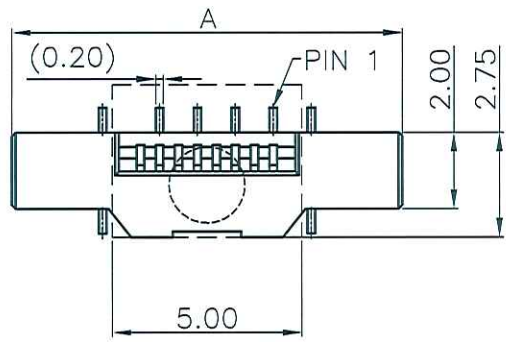
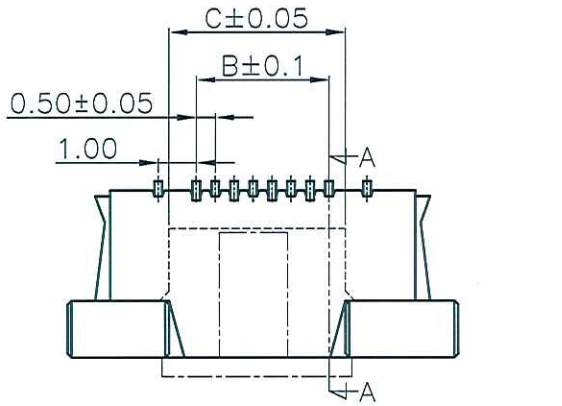

RECOMMENDED P.C. BOARD PATTERN DIM. (REF)

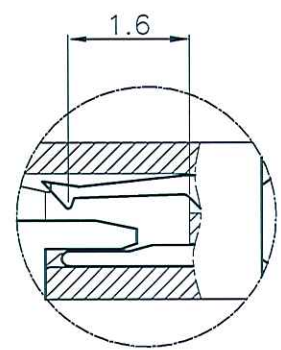
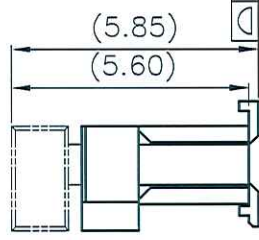
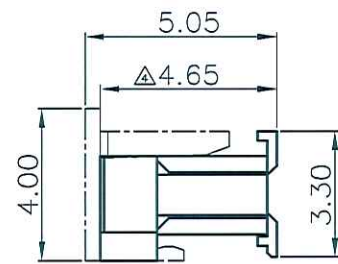

DETAIL "A"
 SCALE=2:1

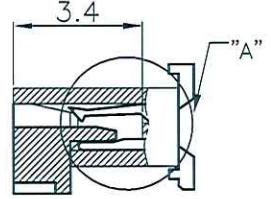

SECTION A-A

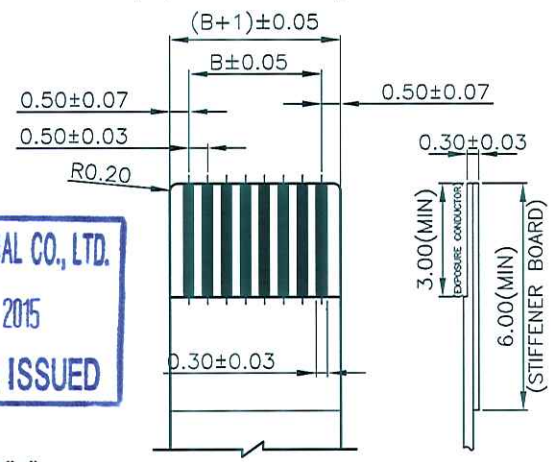

RECOMMENDED APPLICABLE
 FPC LAYOUT

PIN	A	B	C
04	8.50	1.50	2.60
05	9.00	2.00	3.10
06	9.50	2.50	3.60
07	10.00	3.00	4.10
08	10.50	3.50	4.60
09	11.00	4.00	5.10
10	11.50	4.50	5.60
11	12.00	5.00	6.10
12	12.50	5.50	6.60
13	13.00	6.00	7.10
14	13.50	6.50	7.60
15	14.00	7.00	8.10
16	14.50	7.50	8.60
17	15.00	8.00	9.10
18	15.50	8.50	9.60
19	16.00	9.00	10.10
20	16.50	9.50	10.60
21	17.00	10.00	11.10
22	17.50	10.50	11.60
23	18.00	11.00	12.10
24	18.50	11.50	12.60
25	19.00	12.00	13.10
26	19.50	12.50	13.60
27	20.00	13.00	14.10
28	20.50	13.50	14.60
29	21.00	14.00	15.10
30	21.50	14.50	15.60
31	22.00	15.00	16.10
32	22.50	15.50	16.60
33	23.00	16.00	17.10
34	23.50	16.50	17.60
35	24.00	17.00	18.10
36	24.50	17.50	18.60
37	25.00	18.00	19.10
38	25.50	18.50	19.60
39	26.00	19.00	20.10
40	26.50	19.50	20.60
41	27.00	20.00	21.10
42	27.50	20.50	21.60
43	28.00	21.00	22.10
44	28.50	21.50	22.60
45	29.00	22.00	23.10
46	29.50	22.50	23.60
47	30.00	23.00	24.10
48	30.50	23.50	24.60
49	31.00	24.00	25.10
50	31.50	24.50	25.60
51	32.00	25.00	26.10
52	32.50	25.50	26.60
53	33.00	26.00	27.10
54	33.50	26.50	27.60
55	34.00	27.00	28.10
56	34.50	27.50	28.60
57	35.00	28.00	29.10
58	35.50	28.50	29.60
59	36.00	29.00	30.10
60	36.50	29.50	30.60

ENTERY INDUSTRIAL CO., LTD.
 APR - 1, 2015
 R&D D.C.C. ISSUED

CUSTOMER		恩得利工業股份有限公司 ENTERY INDUSTRIAL CO., LTD.	
DRAWN JIMMY SEP-14-2010		PART NO. 6700K-XXXX-06X	
OTHERWISE SPECIFIED X.X ±0.30 X.XX ±0.20 X.XXX ANG. ±0.30'		TITLE: 0.5 ZIF FPC SMT V/T	
APPROVED 		SHEET 1/1	
REVISIONS		UNIT MM	SCALE 5:1
CHK DATE		SIZE A4	REV G

REVISIONS	CHK	DATE
RE201501003	Jun	03/19/15
RE201206014	JIMMY	12/18/12
RE201211006	JIMMY	12/07/12
RE201207010	JIMMY	07/31/12
RE201102011	Joan	03/03/11
REN101012	JIMMY	10/13/10