

1 2 3 4 5 6 7 8 9 0

NOTE:
 1.HOUSING: HIGH-TEMP THERMOPLASTIC UL94V-0,NATURE.
 2.ACTUATOR: HIGH-TEMP THERMOPLASTIC UL94V-0,BLACK.
 3.CONTACT: COPPER ALLOY , PLATING: GLOD FLASH.
 4.FITTING NAIL: COPPER ALLOY, PLATING: MATTE-TIN.
 ORDER INFORMATION: 6714 K-Y XX N - 00 X
 PACKING: R: CARRIER
 E: TUBE
 L: PAPER CARRIER
 TYPE STANDARD
 PIN
 Y: GOLD FLASH (WITH NICKEL BARRIER)
 HALOGEN-FREE MATERIALS
 0.5MM ZIF FPC SMT R/A BOTTOM TYPE

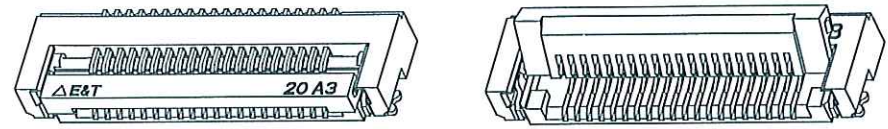
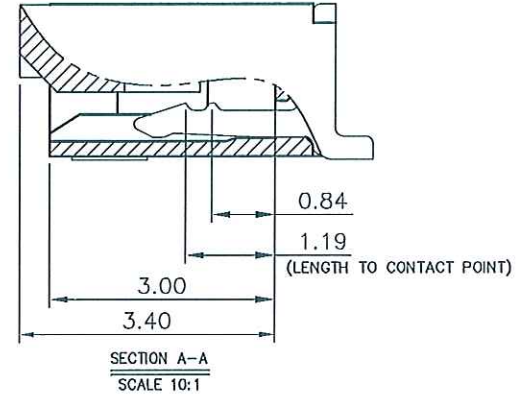
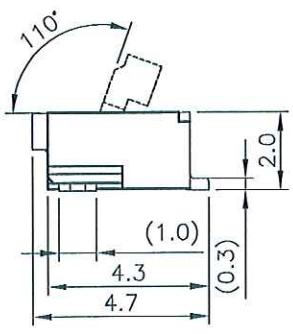
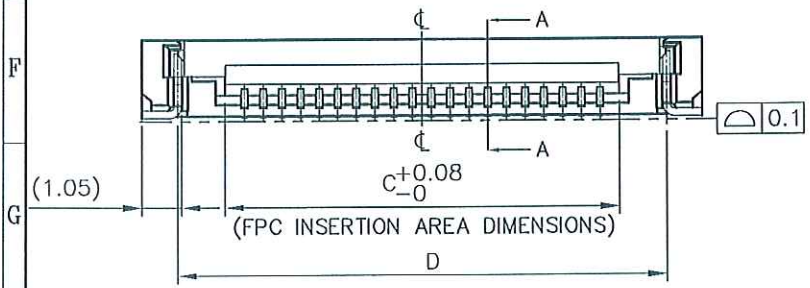
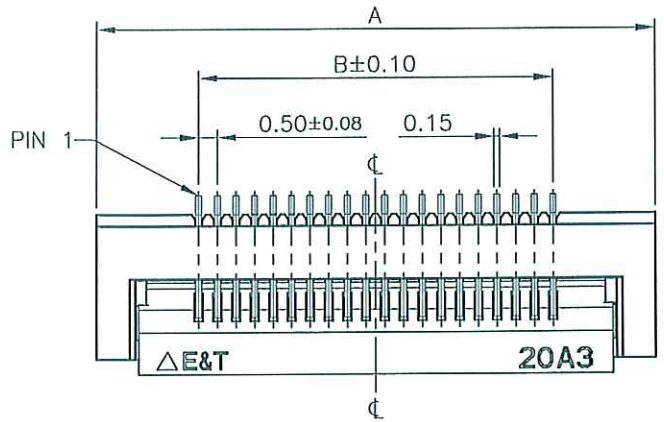

ENTERY INDUSTRIAL CO., LTD.
 MAY - 4. 2012
 R&D D.C.C. ISSUED

PIN NO.	A	B	C	D
20	14.95	9.50	10.55	13.05
30	19.95	14.50	15.55	18.05
40	24.95	19.50	20.55	23.05
50	29.95	24.50	25.55	28.05
60	34.95	29.50	30.55	33.05
80	44.95	39.50	40.55	43.05

CUSTOMER	恩得利工業股份有限公司 E & T ENTERY INDUSTRIAL CO., LTD.	
	DRAWN Jackson JULY-25-2011	PART NO. 6714K-YXXN-00X
SER	MODIFY ALL	JUNO 05/03/12
	ADD TABLE LIST REVISIONS	JACKSON 08/10/11 CHK DATE
GENERAL TOLERANCE UNLESS OTHERWISE SPECIFIED X.X ±0.25 X.XX ±0.15 X.XXX ANG. ±0'30"		TITLE: FPC 0.5P ZIP SMT (EASY-LOCK)
APPROVED SHEET 1/2		UNIT MM SCALE 5:1 SIZE A4 REV B2

1 2 3 4 5 6 7 8 9 0

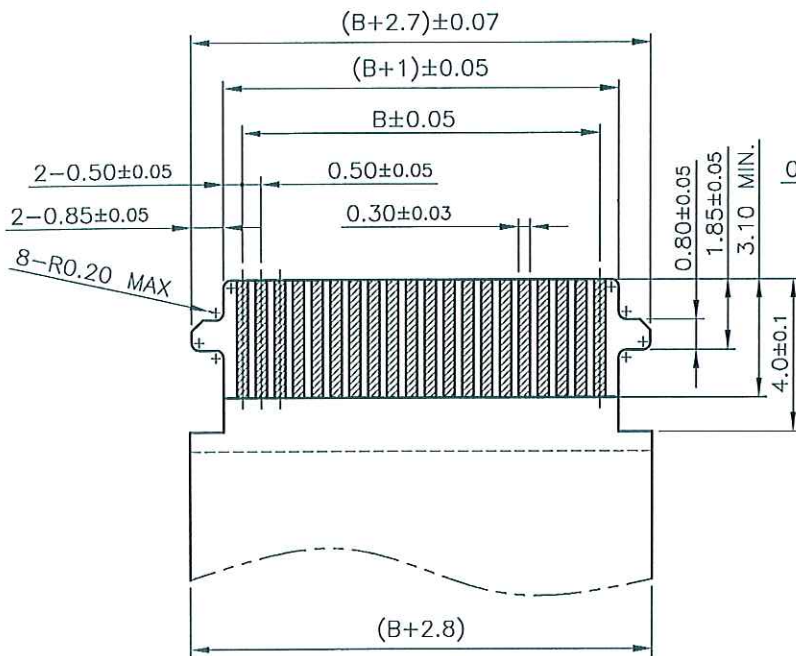

RECOMMENDED FFC DIMENSION

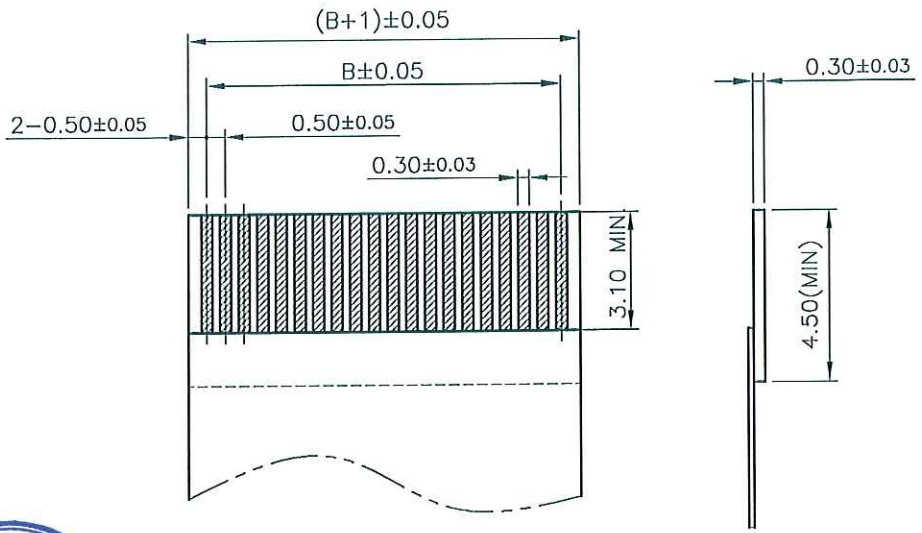

RECOMMENDED FFC DIMENSION

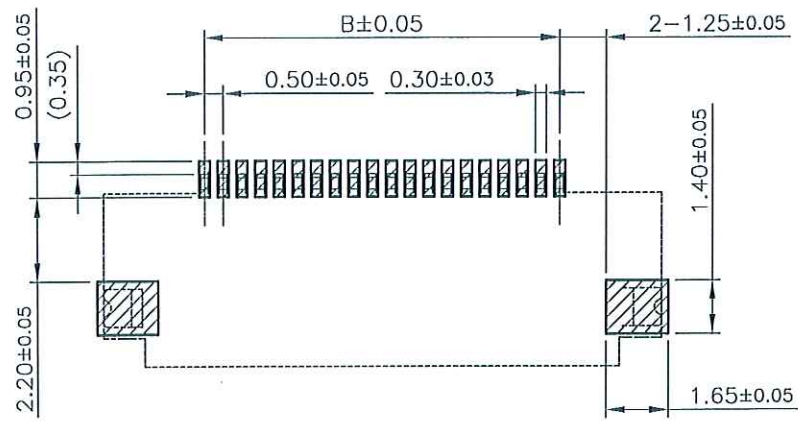

RECOMMENDED PCB LAYOUT (TOP VIEW)

ENTERY INDUSTRIAL CO., LTD.
MAY - 4 2012
R&D D.C.C. ISSUED

PIN NO.	A	B	C	D
20	14.95	9.50	10.55	13.05
30	19.95	14.50	15.55	18.05
40	24.95	19.50	20.55	23.05
50	29.95	24.50	25.55	28.05
60	34.95	29.50	30.55	33.05
80	44.95	39.50	40.55	43.05

CUSTOMER	恩得利工業股份有限公司 ENTERY INDUSTRIAL CO., LTD.	
	DRAWN Jackson JULY-25-2011 CHECKED APPROVED SHEET 2/2	PART NO. 6714K-YXXN-00X TITLE: FPC 0.5P ZIP SMT (EASY-LOCK)
GENERAL TOLERANCE UNLESS OTHERWISE SPECIFIED X.X ±0.25 X.XX ±0.15 X.XXX ANG. ±0°30'	△ MODIFY ALL JUNO 05/03/12 △ ADD TABLE LIST JACKSON 08/10/11' SER REVISIONS CHK DATE	UNIT SCALE SIZE REV MM 5:1 A4 B2