

NOTES: MATERIAL & FINISH

- 1.HOUSING:HIGH-TEMP THERMOPLASTIC UL94V-0,COLOR:NATURE
- 2.ACTUATOR:HIGH-TEMP THERMOPLASTIC UL94V-0,COLOR:BLACK
- 3.TERMINAL:COPPER ALLOY PLATING:GOLD FLASH PLATED
- 4.FITTING NAIL:COPPER ALLOY PLATING:TIN PLATED

ORDER INFORMATION: 6717K - Y XX N-00,01,20,21 X

PACKING:L:PAPER REEL
R:PLASTIC REEL
E:TUBE

TYPE 00: STANDARD
01: STANDARD
△20: CARRIER DIFFERENT
△21: CARRIER DIFFERENT

STANDARD
PIN NO.

PLATING: Y: GOLD FLASH(WITH NICKEL BARRIER) △
0.5 ZIF FPC SMT R/A (HALOGEN FREE)

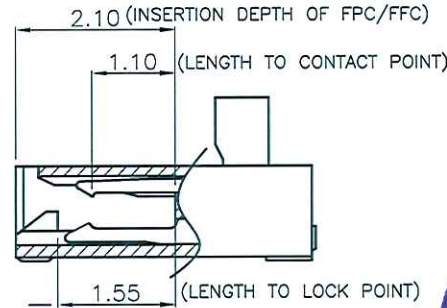
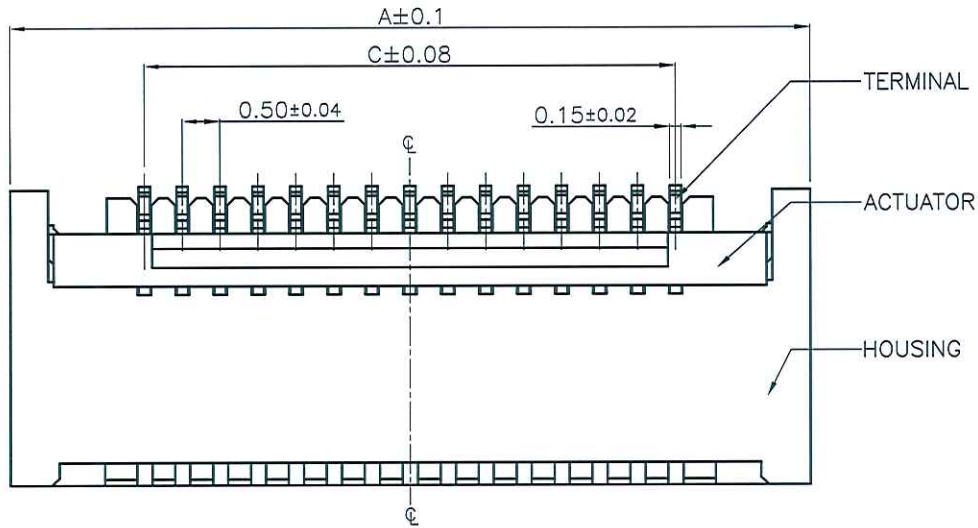

PIN NO.	DIM A	DIM B	DIM C	DIM D
4	5.05	3.75	1.50	4.46
5	5.55	4.25	2.00	4.96
6	6.05	4.75	2.50	5.46
7	6.55	5.25	3.00	5.96
8	7.05	5.75	3.50	6.46
9	7.55	6.25	4.00	6.96
10	8.05	6.75	4.50	7.46
11	8.55	7.25	5.00	7.96
12	9.05	7.75	5.50	8.46
13	9.55	8.25	6.00	8.96
14	10.05	8.75	6.50	9.46
15	10.55	9.25	7.00	9.96
16	11.05	9.75	7.50	10.46
17	11.55	10.25	8.00	10.96
18	12.05	10.75	8.50	11.46
19	12.55	11.25	9.00	11.96
20	13.05	11.75	9.50	12.46
21	13.55	12.25	10.00	12.96
22	14.05	12.75	10.50	13.46
23	14.55	13.25	11.00	13.96
24	15.05	13.75	11.50	14.46
25	15.55	14.25	12.00	14.96
26	16.05	14.75	12.50	15.46
27	16.55	15.25	13.00	15.96
28	17.05	15.75	13.50	16.46
29	17.55	16.25	14.00	16.96
30	18.05	16.75	14.50	17.46

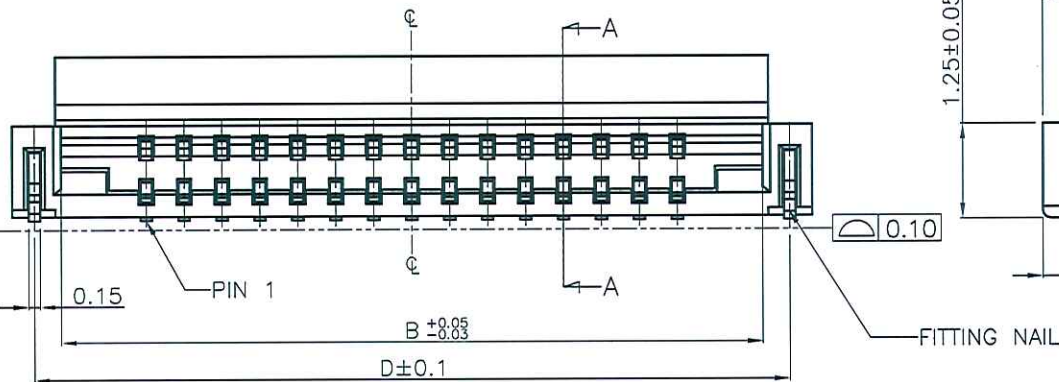

ENTERY INDUSTRIAL CO., LTD.
APR 18. 2014
R&D D.C.C. ISSUED

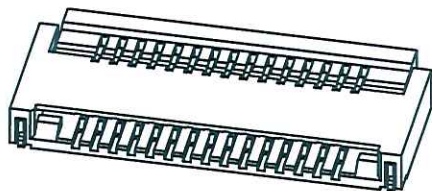

CLOSE STATE

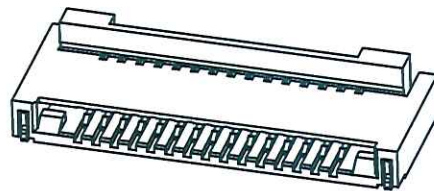

OPEN STATE

CUSTOMER		恩得利工業股份有限公司 E & T ENTERY INDUSTRIAL CO., LTD.	
DRAWN KAZ MAY-18-2012		PART NO. 6717K-YXXN-00,01,20,21X	
CHECKED		TITLE: 0.5 ZIF FPC SMT R/A H1.2	
APPROVED		SHEET 1/2	
GENERAL TOLERANCE UNLESS OTHERWISE SPECIFIED		UNIT SCALE SIZE REV MM 10:1 A4 C	
X.X ±0.25			
X.XX ±0.15			
X.XXX ANG. ±5°			
REVISIONS	CHK	DATE	
△ RE201401007	Juno	03/31/14	
△ RE201303049	Juno	04/28/13	

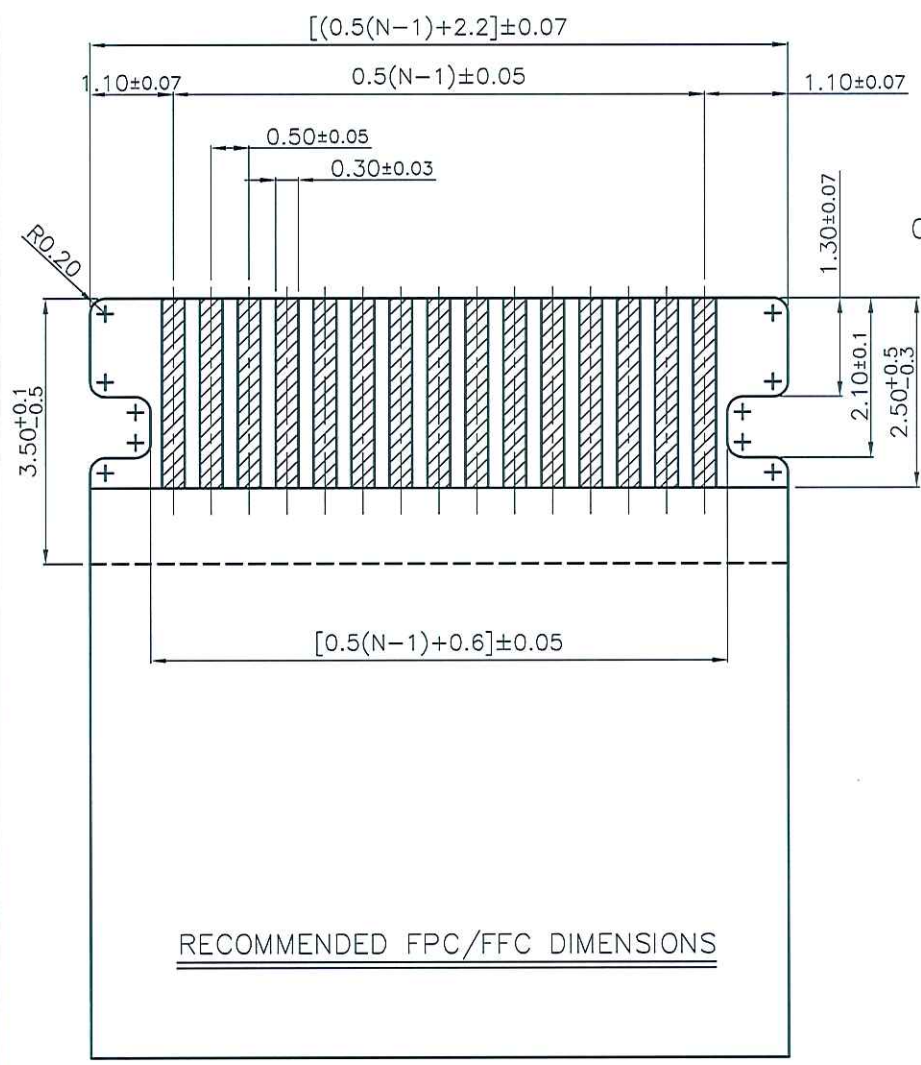

RECOMMENDED FPC/FFC DIMENSIONS

(REINFORCING LAYER)

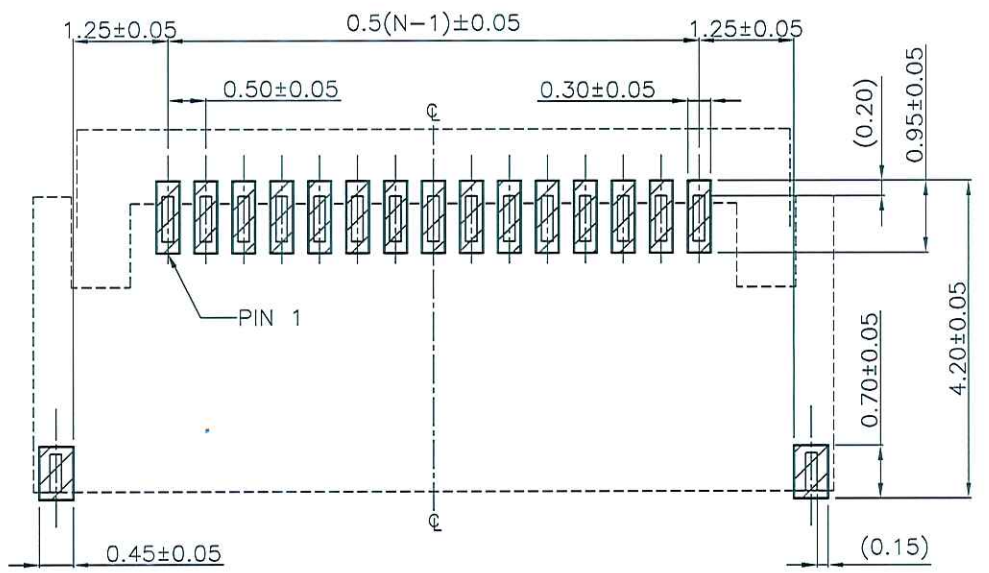

RECOMMENDED PCB MOUNTING PATTERN
TOP VIEW

ENTERY INDUSTRIAL CO., LTD.
 APR 18, 2014
 R&D D.C.C. ISSUED

CUSTOMER 恩得利工業股份有限公司
 E & T ENTERY INDUSTRIAL CO., LTD.

△	RE201401007	Juno	03/31/14
△	RE201303049	Juno	04/28/13
SER	REVISIONS	CHK	DATE

GENERAL TOLERANCE UNLESS OTHERWISE SPECIFIED	DRAWN <i>KAZ MAY-18-2012</i>	PART NO. 6717K-YXXN-00,01,20,21X
X.X ±0.25	CHECKED	TITLE: 0.5 ZIF FPC SMT R/A H1.2
X.XX ±0.15	APPROVED <i>[Signature]</i>	
X.XXX ±0.10		
ANG. ±5°	SHEET 2/2	UNIT MM
		SCALE 10:1
		SIZE A4
		REV C