

NOTES: MATERIAL & FINISH

1. HOUSING: HIGH-TEMP THERMOPLASTIC UL94V-0, COLOR: NATURE
2. ACTUATOR: HIGH-TEMP THERMOPLASTIC UL94V-0, COLOR: BLACK
3. TERMINAL: COPPER ALLOY PLATING: GOLD FLASH PLATED
4. FITTING NAIL: COPPER ALLOY PLATING: TIN PLATED

△ ORDER INFORMATION: 6718K - X XX N-X0,X1 X

ENTERY INDUSTRIAL CO., LTD.
DEC 31. 2014
R&D D.C.C. ISSUED

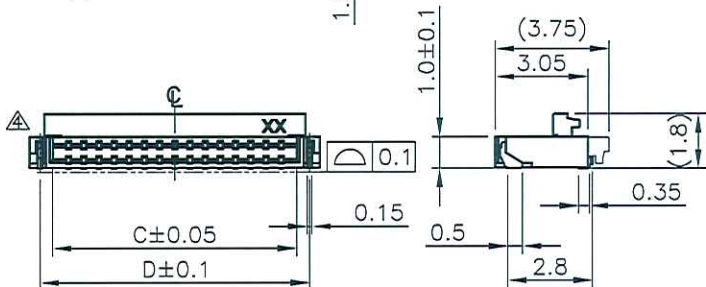
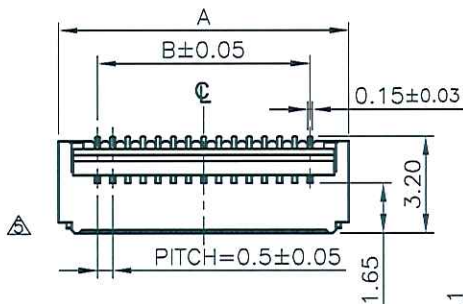

PACKING: L: PAPER REEL
R: PLASTIC REEL
E: TUBE

TYPE: 00,01: CARRIER PITCH 8
20,21: CARRIER PITCH 12 △
TYPE: 10,11: CARRIER PITCH 8
WIDTH DIFFERENT △
TYPE: 30,31: CARRIER PITCH 8
WITH HOLE △
40,41: CARRIER PITCH 12
WIDTH DIFFERENT △

STANDARD PIN NO.

PLATING: Y: HATCHES AREA PLATED GOLD △
FLASH OVERALL 50u~100u "NICKEL UNDER PLATED.

△ Q: MATTE-TIN
△ S: CONTACT AREA 3u"(MIN) GOLD
OTHER AREA GOLD FLASH
△ K: CONTACT AREA 30u"(MIN) GOLD
OTHER AREA GOLD FLASH

0.5 ZIF B.F.A FPC SMT R/A (HALOGEN FREE)
(1.50) (INSERTION DEPTH OF FPC)

SECTION A-A
SCALE 8:1

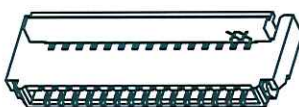
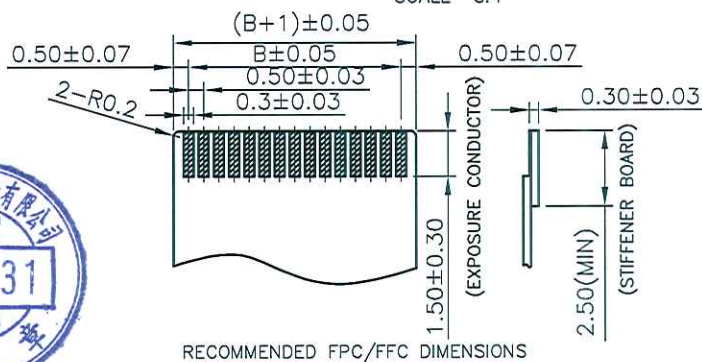
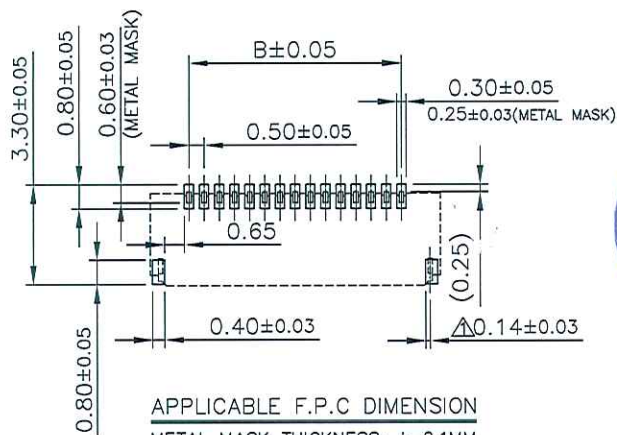

3D VIEW

PIN NO.	DIM.A	DIM.B	DIM.C	DIM.D
4	4.06	1.5	2.55	3.38
5	4.56	2.0	3.05	3.88
6	5.06	2.5	3.55	4.38
7	5.56	3.0	4.05	4.88
8	6.06	3.5	4.55	5.38
9	6.56	4.0	5.05	5.88
10	7.06	4.5	5.55	6.38
11	7.56	5.0	6.05	6.88
12	8.06	5.5	6.55	7.38
13	8.56	6.0	7.05	7.88
14	9.06	6.5	7.55	8.38
15	9.56	7.0	8.05	8.88
16	10.06	7.5	8.55	9.38
17	10.56	8.0	9.05	9.88
18	11.06	8.5	9.55	10.38
19	11.56	9.0	10.05	10.88
20	12.06	9.5	10.55	11.38
21	12.56	10.0	11.05	11.88
22	13.06	10.5	11.55	12.38
23	13.56	11.0	12.05	12.88
24	14.06	11.5	12.55	13.38
25	14.56	12.0	13.05	13.88
26	15.06	12.5	13.55	14.38
27	15.56	13.0	14.05	14.88
28	16.06	13.5	14.55	15.38
29	16.56	14.0	15.05	15.88
30	17.06	14.5	15.55	16.38
31	17.56	15.0	16.05	16.88
32	18.06	15.5	16.55	17.38
33	18.56	16.0	17.05	17.88
34	19.06	16.5	17.55	18.38
35	19.56	17.0	18.05	18.88
36	20.06	17.5	18.55	19.38
37	20.56	18.0	19.05	19.88
38	21.06	18.5	19.55	20.38
39	21.56	19.0	20.05	20.88
40	22.06	19.5	20.55	21.38
41	22.56	20.0	21.05	21.88
42	23.06	20.5	21.55	22.38
43	23.56	21.0	22.05	22.88
44	24.06	21.5	22.55	23.38
45	24.56	22.0	23.05	23.88
46	25.06	22.5	23.55	24.38
47	25.56	23.0	24.05	24.88
48	26.06	23.5	24.55	25.38
49	26.56	24.0	25.05	25.88
50	27.06	24.5	25.55	26.38
51	27.56	25.0	26.05	26.88
52	28.06	25.5	26.55	27.38
53	28.56	26.0	27.05	27.88
54	29.06	26.5	27.55	28.38
55	29.56	27.0	28.05	28.88

CUSTOMER: 恩得利工業股份有限公司
ENTERY INDUSTRIAL CO., LTD.

SER	REVISIONS	CHK	DATE
△	RE201411018	Jun0	12/26/14
△	RE201401007	Jun0	03/05/14
△	RE201401015	Jun0	01/27/14
△	RE201401008 RE201401011	Jun0	01/22/14
△	RE201308009	Jun0	08/20/13
△	RE201301015 RE201301004	Jun0	04/16/13

GENERAL TOLERANCE UNLESS OTHERWISE SPECIFIED	DRAWN KAZ JUL-02-2012	PART NO. 6718K-XXXN-X0,X1X
X.X ±0.25	CHECKED	TITLE: 0.5 PITCH H1.0MM FPC B.F.A,SMT,R/A,D/C TYPE
X.XX ±0.13	APPROVED	SCALE: 4:1
X.XXX ±0.2	SHEET 1/1	UNIT: MM
ANG. ±2°		SIZE: A4
		REV: I