

NOTES: MATERIAL & FINISH

- 1. HOUSING: HIGH THERMOPLASTIC, UL94V-0  
COLOR: BLACK
- 2. LOCK: HIGH THERMOPLASTIC, UL94V-0  
COLOR: WHITE
- 3. CONTACT: COPPER ALLOY  
PLATING: GOLD FLASH OR TIN OVERALL NICKEL UNDER PLATED
- 4. FITTING NAIL: COPPER ALLOY  
PLATING: TIN PLATED

△ 5. ORDER INFORMATION: 6780K-X XX N-01X

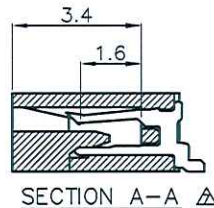

PACKING: E: TUBE  
R: PLASTIC REEL  
△ L: PAPER REEL

STANDARD  
PIN

PLATING: E: TIN  
F: CONTACT GOLD, FITTING NAIL TIN  
△ Q: MATTE-TIN  
△ △ Y AND V: CONTACT HATCHES GOLD, FITTING NAIL TIN

△ 6780K: 0.8 ZIF FPC SMT R/A TYPE TOP CONTACT (HALOGEN FREE)

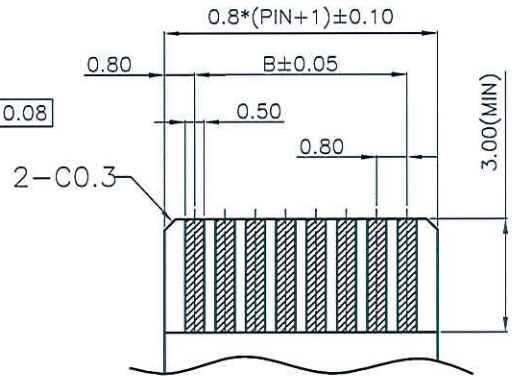
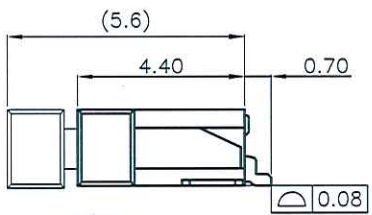
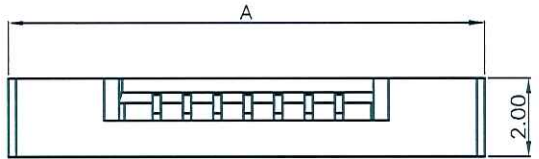

RECOMMENDED APPLICABLE FPC LAYOUT (THICKNESS: 0.3±0.03)

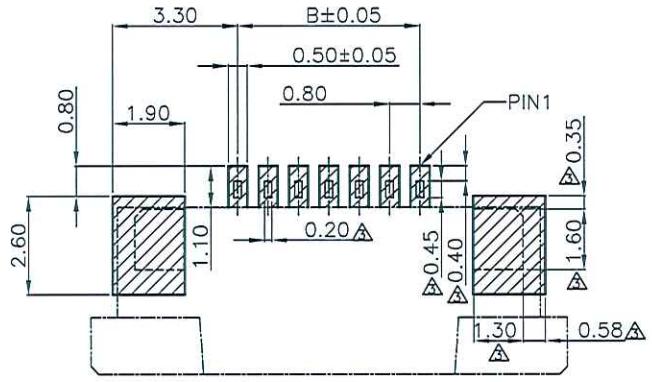

RECOMMENDED P.C. BOARD PATTERN DIM. (REF)



ENTERY INDUSTRIAL CO., LTD.  
JUN - 8. 2013  
R&D D.C.C. ISSUED

PIN	A	B	C
04	10.05	2.40	4.10
05	10.85	3.20	4.90
06	11.65	4.00	5.70
07	12.45	4.80	6.50
08	13.25	5.60	7.30
09	14.05	6.40	8.10
10	14.85	7.20	8.90
11	15.65	8.00	9.70
12	16.45	8.80	10.50
13	17.25	9.60	11.30
14	18.05	10.40	12.10
15	18.85	11.20	12.90
16	19.65	12.00	13.70
17	20.45	12.80	14.50
18	21.25	13.60	15.30
19	22.05	14.40	16.10
20	22.85	15.20	16.90
21	23.65	16.00	17.70
22	24.45	16.80	18.50
23	25.25	17.60	19.30
24	26.05	18.40	20.10
25	26.85	19.20	20.90
26	27.65	20.00	21.70
27	28.45	20.80	22.50
28	29.25	21.60	23.30
29	30.05	22.40	24.10
30	30.85	23.20	24.90
31	31.65	24.00	25.70
32	32.45	24.80	26.50
33	33.25	25.60	27.30
34	34.05	26.40	28.10
35	34.85	27.20	28.90
36	35.65	28.00	29.70
37	36.45	28.80	30.50
38	37.25	29.60	31.30
39	38.05	30.40	32.10
40	38.85	31.20	32.90

SER	REVISIONS	CHK	DATE
△	RE201306027	Juno	07/03/13
△	REN130512	Juno	05/21/13
△	RE201208014	JIMMY	12/20/12
△	RE201210002	JIMMY	02/20/12
△	REN120211	Max	12/16/11
△	REN111215	JIMMY	11/03/11
△	RE201110037	JIMMY	11/03/11

CUSTOMER

恩得利工業股份有限公司  
ENTERY INDUSTRIAL CO., LTD.

DRAWN  
Juno APR-17-2007

CHECKED

APPROVED  
7/6/13

SHEET

PART NO. △  
6780K-XXXN-01X

TITLE:  
0.8 ZIF FPC SMT R/A TYPE TOP CONTACT

UNIT: MM  
SCALE: 5:1  
SIZE: A4  
REV: H