

NOTES: MATERIAL & FINISH

- 1.HOUSING:HIGH-TEMP THERMOPLASTIC UL94V-0,COLOR:NATURE
- 2.ACTUATOR:HIGH-TEMP THERMOPLASTIC UL94V-0,COLOR:BLACK
- 3.TERMINAL:COPPER ALLOY PLATING:GOLD FLASH PLATED
- 4.FITTING NAIL:COPPER ALLOY PLATING:TIN PLATED

ORDER INFORMATION: 6918K - X XX N-00 X

PACKING:L:PAPER REEL
R:PLASTIC REEL
E:TUBE

TYPE

STANDARD
PIN NO.

PLATING: Y:HATCHES AREA PLATED GOLD FLASH
OVERALL 50u~100u" NICKEL UNDER PLATED.
Q:MATTE-TIN

1.0 PITCH ZIF B.F.A FPC SMT R/A (HALOGEN FREE)

PIN NO.	DIM.A	DIM.B	DIM.C	DIM.D
4	6.56	3.0	5.03	5.88
5	7.56	4.0	6.03	6.88
6	8.56	5.0	7.03	7.88
7	9.56	6.0	8.03	8.88
8	10.56	7.0	9.03	9.88
9	11.56	8.0	10.03	10.88
10	12.56	9.0	11.03	11.88
11	13.56	10.0	12.03	12.88
12	14.56	11.0	13.03	13.88
13	15.56	12.0	14.03	14.88
14	16.56	13.0	15.03	15.88
15	17.56	14.0	16.03	16.88

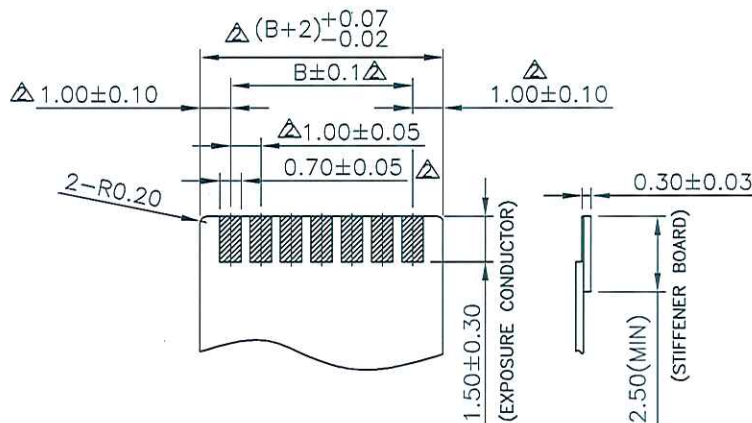
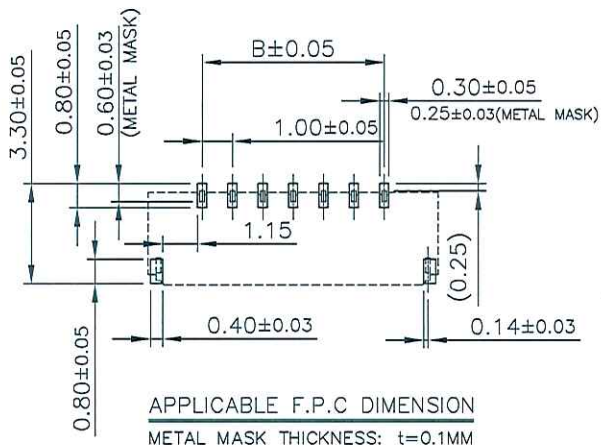
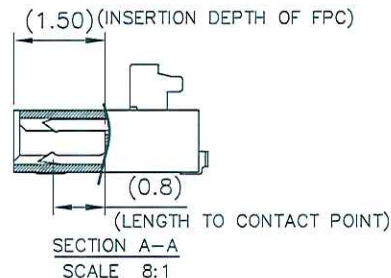
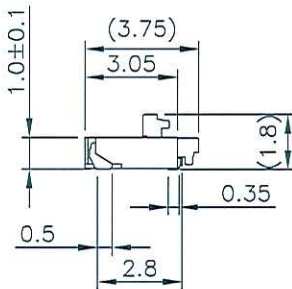
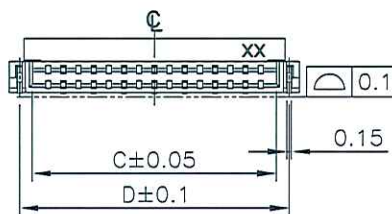
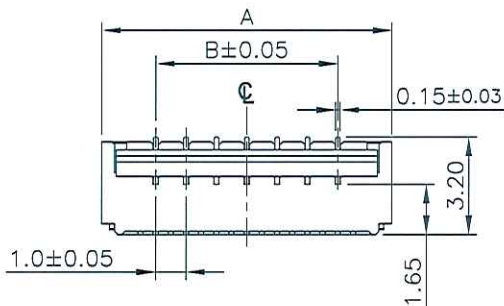

RECOMMENDED FPC/FFC DIMENSIONS

ENTERY INDUSTRIAL CO., LTD.
SEP 16. 2014
R&D D.C.C. ISSUED

CUSTOMER



恩得利工業股份有限公司
ENTERY INDUSTRIAL CO., LTD.

GENERAL TOLERANCE UNLESS OTHERWISE SPECIFIED
X.X ±0.25
X.XX ±0.13
X.XXX
ANG. ±2'

DRAWN
Josh MAY-26-2014
CHECKED

PART NO.
6918K-XXXN-00X

APPROVED
9/3/14

TITLE:
1.0 PITCH H1.0MM FPC
B.F.A,SMT,R/A,D/C TYPE

REVISIONS	CHK	DATE
RE201408010	Juno	09/01/14
RB131201	Juno	05/20/14

SHEET	UNIT	SCALE	SIZE	REV
1/1	MM	4:1	A4	B