

TO

SPECIFICATION FOR APPROVAL

DESCRIPTION: Pitch 0.50mm ZIF FPC Connector, R/A, SMT Type Bottom Contact

CUSTOMER PROD.NO/DWG.NO:

E&T PROD.NO: 6702K-XXXX-XXX

APPROVAL SHEET NO:

E&T DWG. NO./DOCUMENT: 6702K-XXXX-XXX

REV: A8

PLEASE RETURN TO US ONE COPY OF "SPECIFICATION FOR APPROVAL" WITH YOUR APPROVED SIGNATURES.

APPROVED SIGNATURES			



**ENTERY INDUSTRIAL CO., LTD.
E&T ELECTRONICS (DONG GUAN) CO., LTD.
E&T ELECTRONICS (SU ZHOU) CO., LTD.
E&T ELECTRONICS (NANKEEN)CO.,LTD.**

ENTERY INDUSTRIAL CO., LTD.

**Title : Pitch 0.50mm ZIF FPC Connector,
R/A, SMT Type Bottom Contact**

**RELEASE
HISTORY**

Title: Pitch 0.50mm ZIF FPC Connector, R/A, SMT Type Bottom Contact

Rev	Description
A8	2013/5/21

This Document Contains Information That Is Proprietary To
E&T And Should Not Be Used Without Written Permission

Document No.
6702K-XXXX-XXX

Prepared By: Joan Huang

Date: 05,14,2009'

Checked By:

Date: 05,21,2013'

Approved By:

Date:

ENTERY INDUSTRIAL CO., LTD.

PRODUCT SPECIFICATION

1. SCOPE :

This specification covers the pitch 0.50 mm ZIF FPC connector series.

2. PRODUCT NAME AND PART NUMBER :

Product Name	E&T Part Number
0.50mm ZIF FPC Connector, R/A, SMT Type Bottom Contact	6702K-XXXX-XXX

3. RATINGS :

Item	Standard	
Rated Voltage (MAX.)	50 V	AC(rms)/DC
Rated Current (MAX.)	0.5A	
Operating Temperature Range	-40 ⁰ C ~ +85 ⁰ C	

*Including terminal temperature rise

4.PERFORMANCE :

4- 1 Electrical Performance

Item	Test Condition	Requirement
4-1-1 Contact Resistance	Test Current: 1 mA Max. Test Voltage: 20mV Max Test Method:EIA-364-06B	50 mΩ MAX.
4-1-2 Insulation Resistance	Test Voltage: 100V DC. Test Duration: 1 minutes. Test Method:EIA-364-21C	Initial: 500 MΩ Min
		Final: 100 MΩ Min.
4-1-3 Dielectric Strength	Test Voltage: 200V AC. Test Time: 60 sec. Test Method:EIA-364-09C	No Breakdown

ENTERY INDUSTRIAL CO., LTD.

4-2 Mechanical Performance

Item		Test Condition	Requirement
4-2-1	FPC Retention Force	Test Speed: 25±3 mm/min. Test Method:EIA-364-38B	0.035kgf / per pin
4-2-2	Terminal / Housing Retention Force	Test Speed: 25mm/min.	0.1kgf (Min)

4-3 Environmental Performance and Others

Item		Test Condition	Requirement	
4-3-1	Durability	Insert and withdraw actuator up to 30cycles at the speed rate of less than 10 cycles/minute. Test Method:EIA-364-09C	Contact Resistance	
			Initial Value	≤ 50 mΩ
			Final Value	≤ 80 mΩ
4-3-2	Vibration	Amplitude : 1.5 mm Frequency range: 10~55~10 Hz in 1 minute Duration: 2 hours in each X.Y.Z axes Current: 100mA. Test Method:EIA-364-28D	Appearance	No Damage
			Contact Resistance	≤ 80 mΩ
			Discontinuity	1μsec
4-3-4	Heat Resistance	Temperature: 80±2℃ Duration: 96 hours	Appearance	No Damage
			Contact Resistance	≤ 80 mΩ
4-3-5	Cold Resistance	Temperature: -40±2℃ Duration: 96 hours	Appearance	No Damage
			Contact Resistance	≤ 80 mΩ
4-3-6	Humidity	Temperature: 40±2℃ Relative Humidity: 90~95% Duration: 96 hours Test Method:EIA-364-31B	Appearance	No Damage
			Contact Resistance	≤ 80 mΩ
			Insulation Resistance	≥ 100MΩ
			Dielectric Strength	Must meet 4-1-3

ENTERY INDUSTRIAL CO., LTD.

5. INFRARED REFLOW CONDITION

- 1) Ascending time to preheating temperature 170°C shall be 40 seconds minimum.
- 2) Preheating shall be fixed at 160...180°C for 60...90 seconds.
- 3) Heating shall be fixed at 220°C for 50...60 seconds.
- 4) At 260±5°C peak shall be 10 seconds maximum.

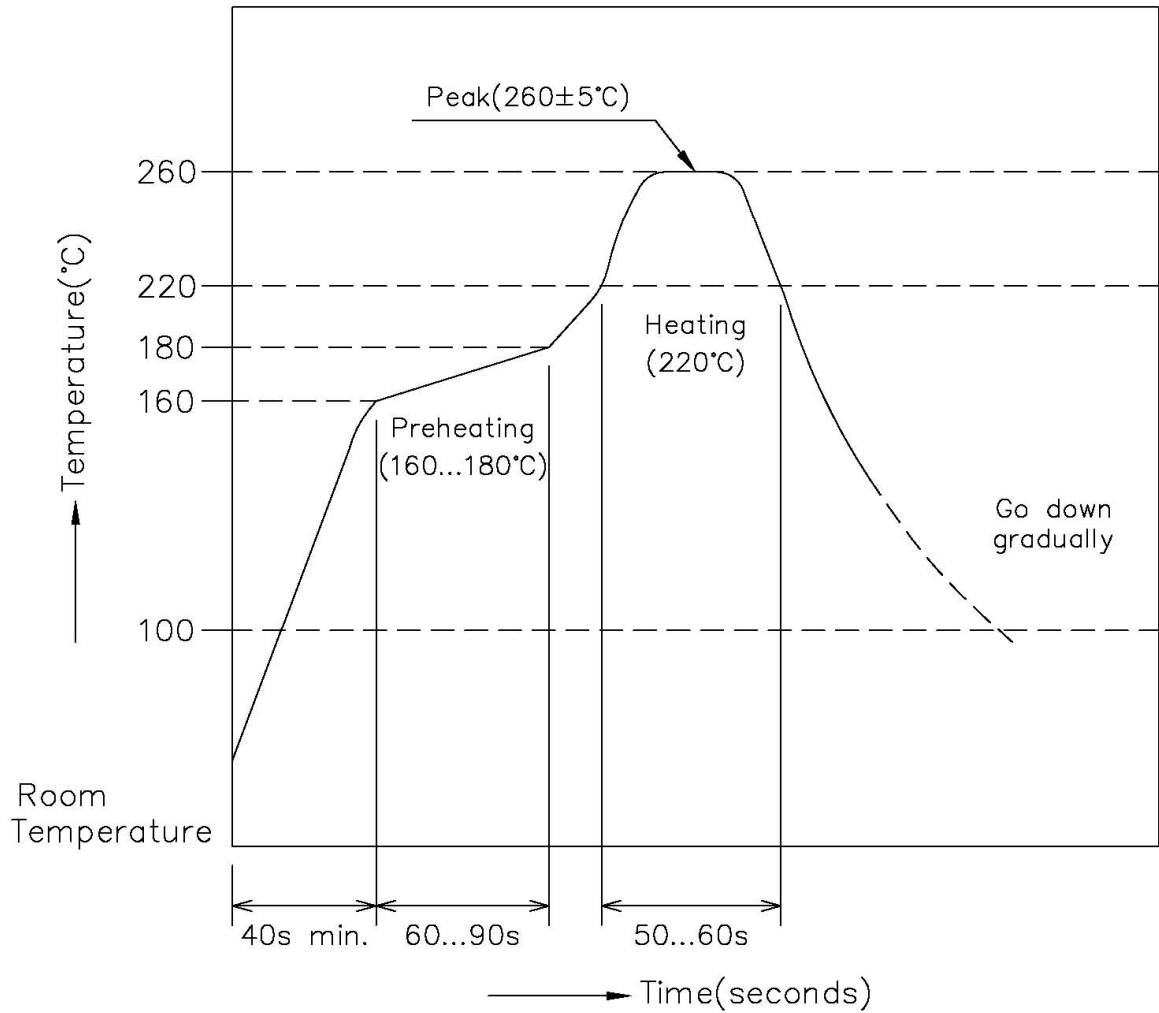

FPC /FFC Connector Slip Lock Type Handling Precautions

This manual is to describe basic precautions. When there are doubtful points in use of, please contact E&T.

1. Common Handling Precautions

- Do not expose E&T's ZIF FPC/FFC connector, processing process product and processing product to corrosive substance, corrosive gas, high temperature and high humidity and direct sunshine. It causes corrosion of contact and deterioration of insulation performance of housing, etc., so that it causes motion defect of appliances.
- Do not apply external load to E&T's ZIF FPC/FFC connector, processing process product and processing product . Deformation and breakage, etc. occur, and it causes performance defect of.
- There may be slight differences in the housing coloring, but there will be no influence on the product's performance.
- Please add a stiffener on the flexible printed circuit (FPC/FFC) when you mount the connector onto FPC in order to prevent deformation of the FPC/FFC.
- Please do not conduct any "washing process" on the connector because it may damage the product's function.

2. PC Board Precautions

- Exercise caution when handling boards with the connectors installed. Do not apply any forces affecting soldered joints. (see figure 1).
- The mounting specification for coplanarity does not include the influence of warpage of the printed circuit board. (see figure 1).

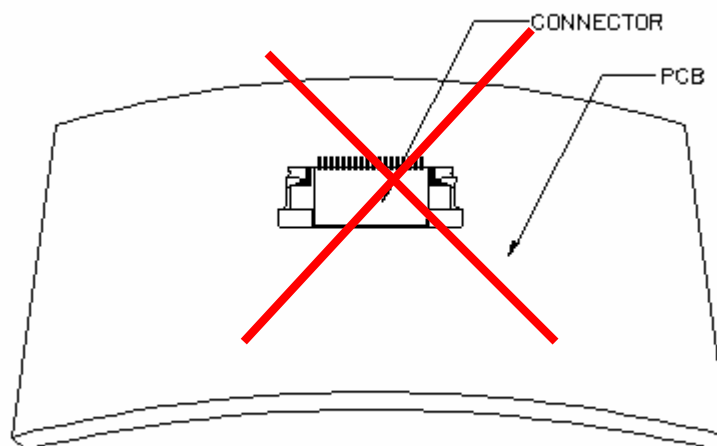

Figure 1.

3. Operation

FPC/FFC Insertion Procedure.

- 1) Connector installed on the board.
Seize the actuator(Lock) to pull out. Use thumb and index finger. (see figure 2).

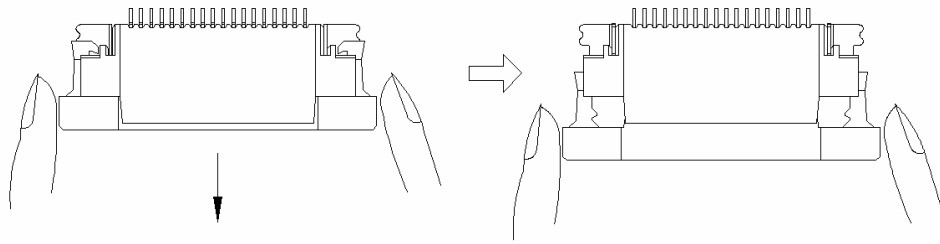

Figure 2.

- 2) Assure that the FPC/FFC is fully inserted parallel to mounting surface. (see figure 3)

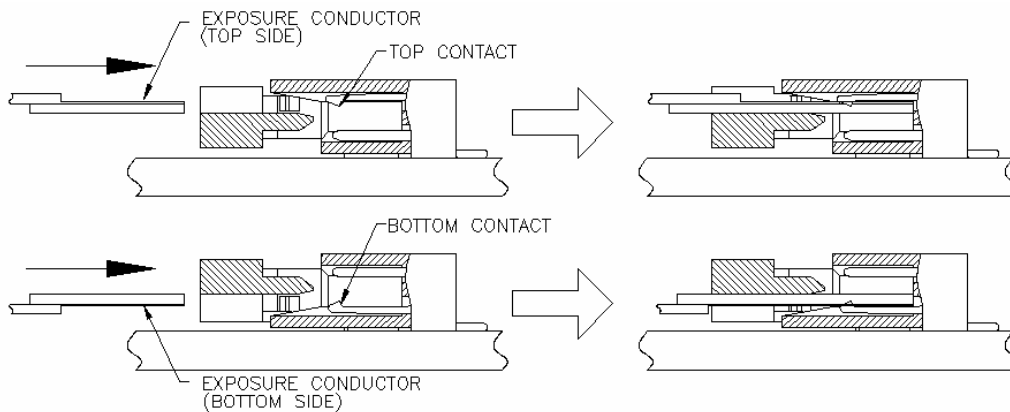

Figure 3.

- 3) Push the actuator(Lock) until firmly closed. It is critical that the inserted FPC is not moved and remains fully inserted. Should the FPC be moved, open the actuator(Lock) and repeat the process, starting with Step 1(see figure 4).

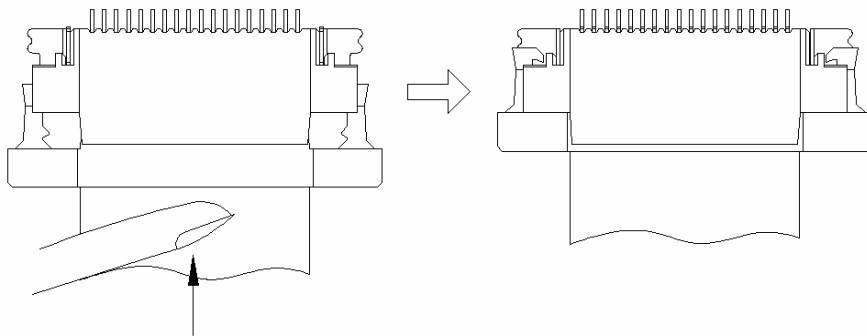

Figure 4.

FPC/FFC Removal.

- 1) Seize the actuator(Lock) to pull out. Use thumb and index finger. (see figure 5).
- 2) Carefully withdraw the FPC/FFC. (see figure 5).

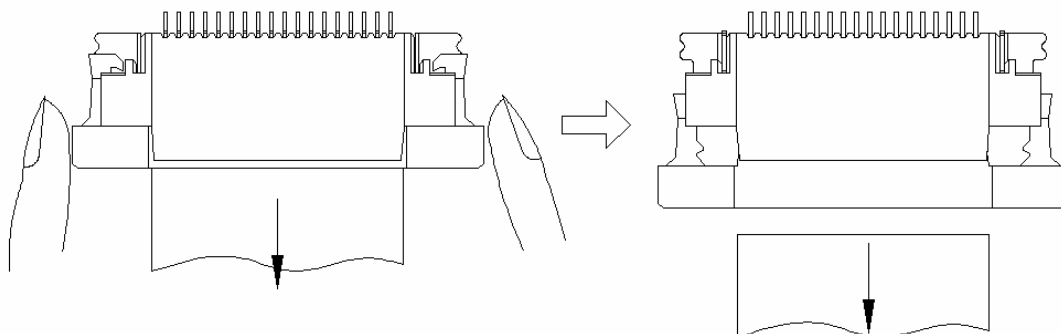

Figure 5.

4. Precautions When Inserting or Withdrawal FPC/FFC

- FPC/FFC to be insertion and withdrawal at an angle of about 15° , and the FPC/FFC should be inserted firmly all the way to the back. (see figure 6).

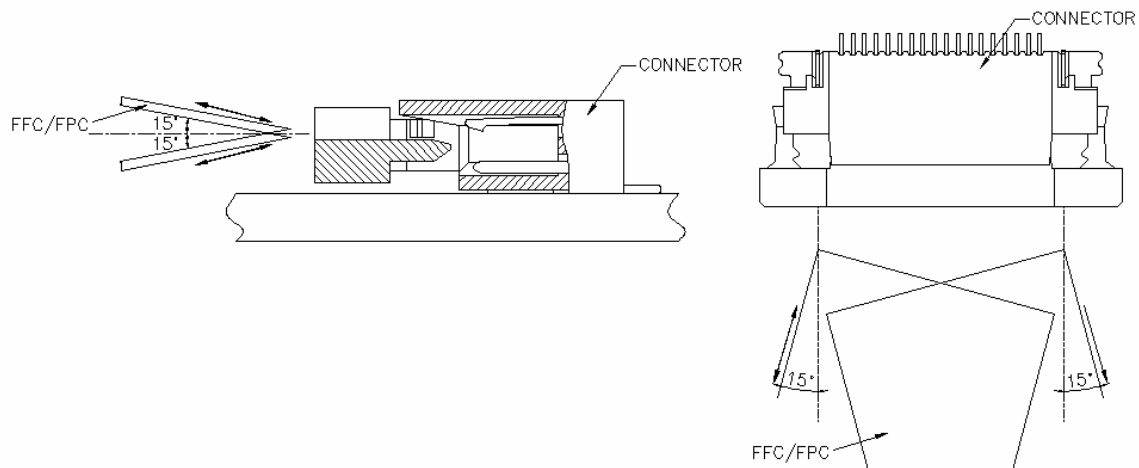

Figure 6.

- If necessary, please fix the FPC/FFC directly on the chassis. Also, please avoid pulling the FPC/FFC vertically or twisting the FPC back and force horizontally while it is inserted in the connector(see figure 7).
- Forming processing is conducted to FPC so as not to load force to connector. (see figure 7).

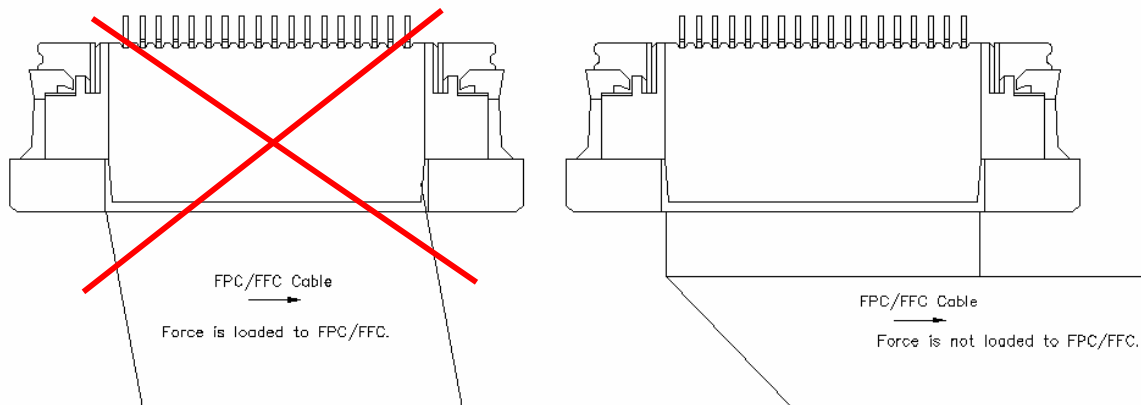

Figure 7.

ENTERY INDUSTRIAL CO., LTD.

RELEASE HISTORY

Rev.	Revisions	Date	Executor	Description
A2	RE201108011	Aug-18-2011	Juno	Add Handling Precautions.
A3	RE201111028	DEC-08-2011	Juno	Modify Handling Precautions Cancel Packaging
A4	RE201206006	JUN-18-2012	JIMMY	CHANGE FPC Retention Force
A5	REN120807	AUG-10-2012	JIMMY	Modify Ambient Temperature Range
A6	RE201210019	NOV-02-2012	JIMMY	Add 20 type
A7	REN130209	FEB-19-2013	Juno	Modify Rated Voltage& Current unit.
A8	RE201305001	MAY-21-2013	Juno	Add P/N.