

TO

SPECIFICATION FOR APPROVAL

DESCRIPTION: Pitch 1.00mm ZIF FPC Connector, V/T, SMT Type Low Profile

CUSTOMER PROD.NO/DWG.NO:

E&T PROD.NO: 6904K-XXXX-00X

APPROVAL SHEET NO:

E&T DWG. NO./DOCUMENT: 6904K-XXXX-00X

REV: A2

PLEASE RETURN TO US ONE COPY OF "SPECIFICATION FOR APPROVAL" WITH YOUR APPROVED SIGNATURES.

APPROVED SIGNATURES			

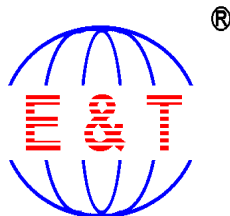



The Quality Connection

**ENTERY INDUSTRIAL CO., LTD.
E&T ELECTRONICS (DONG GUAN) CO., LTD.
E&T ELECTRONICS (SU ZHOU) CO., LTD.**

ENTERY INDUSTRIAL CO., LTD.

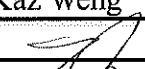
**Title :Pitch 1.00mm ZIF FPC Connector,
V/T, SMT Type Low Profile**

REN150401		Title: Pitch 1.00mm ZIF FPC Connector, V/T, SMT Type Low Profile	
A1	2015/4/1	This Document Contains Information That Is Proprietary To E&T And Should Not Be Used Without Written Permission	
Rev	Description		
Document No.		Prepared By: Kaz Weng	Date: 09,06,2012
6904K-XXXX-00X		Checked By: 	Date: 07-20-2015
		Approved By: 	Date:

ENTERY INDUSTRIAL CO., LTD.

PRODUCT SPECIFICATION

1. SCOPE :

This specification covers the Pith 1.00 mm ZIF FPC Connector series.

2. PRODUCT NAME AND PART NUMBER :

Product Name	E&T Part Number
1.00mm ZIF FPC Connector, V/T, SMT Type Low Profile	6904K-XXXX-00X

3. RATINGS :

Item	Standard	
Rated Voltage (MAX.)	125 V	(AC (rms / DC))
Rated Current (MAX.)	1 A	
Ambient Temperature Range	-20 ⁰ C ~ +85 ⁰ C	

*1. Including terminal temperature rise .

4. PERFORMANCE :

4 - 1 Electrical Performance

Item		Test Condition	Requirement
4-1-1	Contact Resistance	Mate applicable FPC and measure by dry circuit , 20mV MAX., 10 mA . (Based upon JIS C5402 5.4)	20 mΩ MAX.
4-1-2	Insulation Resistance	Mate applicable FPC and apply 500V DC between adjacent terminal or ground. (Based upon JIS C5402 5.2 / MIL- STD -202 Method 302 Cond.B)	100MΩ MIN.
4-1-3	Dielectric Strength	Mate applicable FPC and apply 500V AC (rms) for 1 minute between adjacent terminal or ground. (Based upon JIS C5402 5.1/MIL- STD -202 Method 301)	No Breakdown

ENTERY INDUSTRIAL CO., LTD.

4-2 Mechanical Performance

Item		Test Condition	Requirement
4-2-1	FPC/ Retention Force	Insert the actuator, pull the FPC at the speed rate of 25 ± 3 mm / minute.	Refer to paragraph 6
4-2-2	Terminal/ Housing Retention Force	Apply axial pull out force at the speed rate of 25 ± 3 mm / minute on the terminal assembled in the housing.	{ 0.4kgf } MAX.

4-3 Environmental Performance and Others

Item		Test Condition	Requirement	
4-3-1	Durability	Insert and withdraw actuator up to 30 cycles at the speed rate of less than 10 cycles/minute.	Contact Resistance : $40 \text{ m}\Omega$ MAX.	
4-3-3	Vibration	Amplitude : 1.5 mm P-P Sweep time : 10-55-10 Hz in 1 minute Duration : 2 hours in each X.Y.Z. axes (Based upon MIL-STD-202 Method 201A)	Appearance	No Damage
			Contact Resistance	$\leq 40 \text{ m}\Omega$
			Discontinuity	$1 \mu\text{sec}$
4-3-4	Heat Resistance	Temperature: $85 \pm 2^\circ\text{C}$ Duration: 96 hours Test Method: MIL-STD-202, Method 108.	Appearance	No Damage
			Contact Resistance	$\leq 40 \text{ m}\Omega$
4-3-5	Cold Resistance	Temperature: $-40 \pm 2^\circ\text{C}$ Duration: 96 hours Test Method: JIS C60068-2-1	Appearance	No Damage
			Contact Resistance	$\leq 40 \text{ m}\Omega$
4-3-6	Humidity	Temperature: $40 \pm 2^\circ\text{C}$ Relative Humidity: 90~95% Duration: 96 hours Test Method: MIL-STD-202F , Method 103	Appearance	No Damage
			Contact Resistance	$\leq 60 \text{ m}\Omega$
			Insulation Resistance	$\geq 20 \text{ M}\Omega$
			Dielectric Strength	Must meet 4-1-3
4-3-7	Temperature Rise Test	Carrying rated current load. EIA-364-70B	Temperature Rise : 30°C (MAX)	

ENTERY INDUSTRIAL CO., LTD.

Item		Test Condition	Requirement	
4-3-8	Temperature Cycling	32 cycles of : a) - 55 ±3°C 30 minutes b)+ 25 ±3°C 30 minutes c)+ 85 ±2°C 30 minutes (Based upon JIS C0025)	Appearance	No Damage
4-3-9	Salt Spray	48±4 hours exposure to a salt spray from the 5±1% solution at 35±2°C . (Based upon JIS C5028/MIL-STD-202 Method 101D Condition . B)	Appearance	No Damage
4-3-10	Solder ability	Soldering Time : 3±0.5 sec Solder Temperature : 245±5°C Test Method: MIL-STD-202F , Method 208G	Solder Wetting	95% of immersed area must show no voids, pin holes
4-3-11	Resistance To Soldering Heat	Soldering iron method Solder Time : 3±0.5 sec Solder Temperature: 350±10°C However, without too much pressure to the terminal pin. EIA-364-56D	Appearance	No Damage
		Using the reflow profile condition below paragraph 5. The product was reflowed two times.		

ENTERY INDUSTRIAL CO., LTD.

5. PRODUCT SHAPE, DIMENSIONS AND MATERIALS (Refer to the drawing.)

6. 1.00mm FPC RETENTION FORCE SPEC

No. of CKT	UNIT	Retention Force(MIN.)		No. of CKT	UNIT	Retention Force(MIN.)	
		1st	10th			1th	10th
4	N Kg f	4.90 { 0.500 }	4.10 { 0.400 }	18	N Kg f	8.40 { 0.850 }	7.40 { 0.750 }
5	N Kg f	5.15 { 0.525 }	4.30 { 0.425 }	19	N Kg f	8.65 { 0.875 }	7.65 { 0.775 }
6	N Kg f	5.40 { 0.550 }	4.50 { 0.450 }	20	N Kg f	8.90 { 0.900 }	7.90 { 0.800 }
7	N Kg f	5.65 { 0.575 }	4.70 { 0.475 }	21	N Kg f	9.15 { 0.925 }	8.15 { 0.825 }
8	N Kg f	5.90 { 0.600 }	4.90 { 0.500 }	22	N Kg f	9.40 { 0.950 }	8.40 { 0.850 }
9	N Kg f	6.15 { 0.625 }	5.15 { 0.525 }	23	N Kg f	9.65 { 0.975 }	8.65 { 0.875 }
10	N Kg f	6.40 { 0.650 }	5.40 { 0.550 }	24	N Kg f	9.80 { 1.000 }	8.90 { 0.900 }
11	N Kg f	6.65 { 0.675 }	5.65 { 0.575 }	25	N Kg f	10.05 { 1.025 }	9.15 { 0.925 }
12	N Kg f	6.90 { 0.700 }	5.90 { 0.600 }	26	N Kg f	10.30 { 1.050 }	9.40 { 0.950 }
13	N Kg f	7.15 { 0.725 }	6.15 { 0.625 }	27	N Kg f	10.55 { 1.075 }	9.60 { 1.975 }
14	N Kg f	7.40 { 0.750 }	6.40 { 0.650 }	28	N Kg f	10.80 { 1.100 }	9.80 { 1.000 }
15	N Kg f	7.65 { 0.775 }	6.65 { 0.675 }	29	N Kg f	11.05 { 1.125 }	10.05 { 1.025 }
16	N Kg f	7.90 { 0.800 }	6.90 { 0.700 }	30	N Kg f	11.30 { 1.150 }	10.30 { 1.050 }
17	N Kg f	8.15 { 0.825 }	6.15 { 0.725 }				

ENTERY INDUSTRIAL CO., LTD.

INFRARED REFLOW CONDITION

- 1) Ascending time to preheating temperature 170°C shall be 40 seconds minimum.
- 2) Preheating shall be fixed at 160...180°C for 60...90 seconds.
- 3) Heating shall be fixed at 220°C for 50...60 seconds.
- 4) At 260±5°C peak shall be 10 seconds maximum.

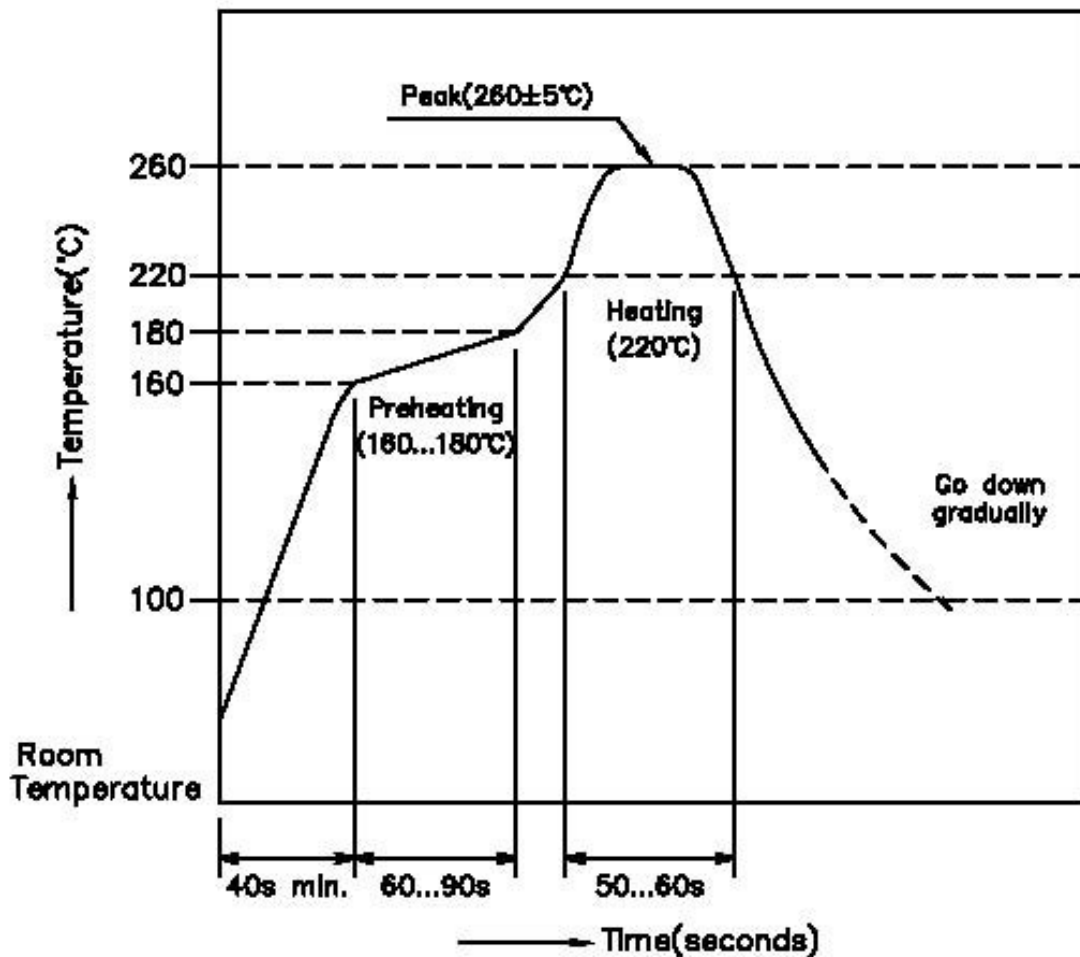

FPC /FFC Connector Slip Lock Type Handling Precautions

This manual is to describe basic precautions. When there are doubtful points in use of, please contact E&T.

1. Common Handling Precautions

- Do not expose E&T's ZIF FPC/FFC connector, processing process product and processing product to corrosive substance, corrosive gas, high temperature and high humidity and direct sunshine. It causes corrosion of contact and deterioration of insulation performance of housing, etc., so that it causes motion defect of appliances.
- Do not apply external load to E&T's ZIF FPC/FFC connector, processing process product and processing product . Deformation and breakage, etc. occur, and it causes performance defect of.
- There may be slight differences in the housing coloring, but there will be no influence on the product's performance.
- Please add a stiffener on the flexible printed circuit (FPC/FFC) when you mount the connector onto FPC in order to prevent deformation of the FPC/FFC.
- Please do not conduct any "washing process" on the connector because it may damage the product's function.

2. PC Board Precautions

- Exercise caution when handling boards with the connectors installed. Do not apply any forces affecting soldered joints. (see figure 1).
- The mounting specification for coplanarity does not include the influence of warpage of the printed circuit board. (see figure 1).

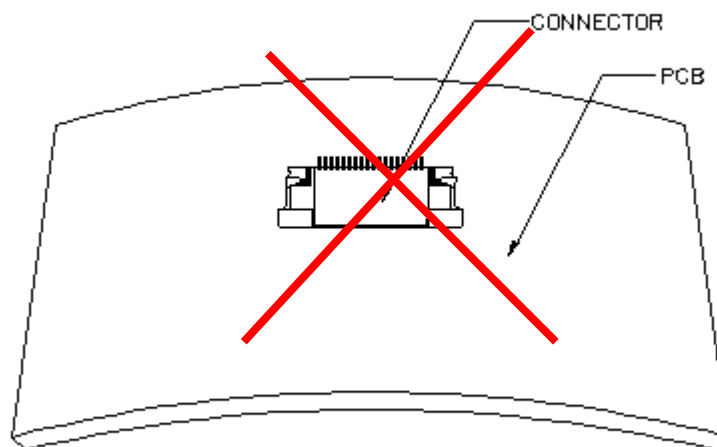

Figure 1.

3. Operation

FPC/FFC Insertion Procedure.

- 1) Connector installed on the board.
Seize the actuator(Lock) to pull out. Use thumb and index finger. (see figure 2).

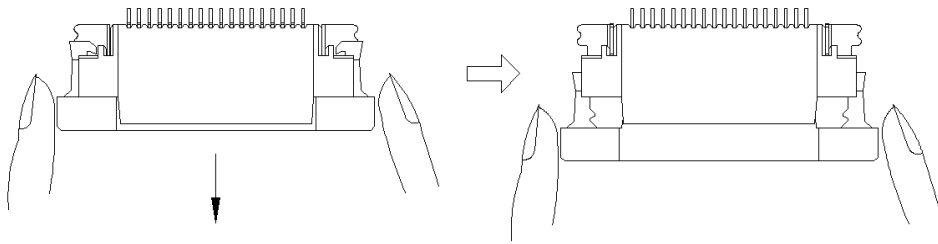

Figure 2.

- 2) Assure that the FPC/FFC is fully inserted parallel to mounting surface. (see figure 3)

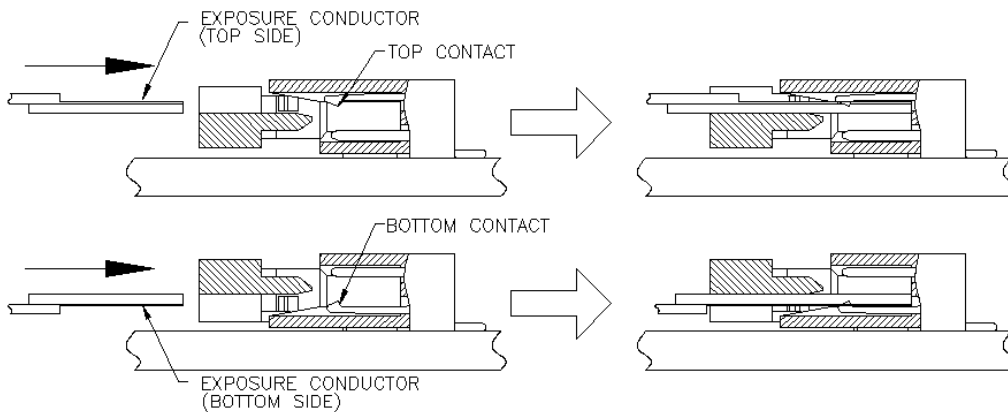

Figure 3.

- 3) Push the actuator(Lock) until firmly closed. It is critical that the inserted FPC is not moved and remains fully inserted. Should the FPC be moved, open the actuator(Lock) and repeat the process, starting with Step 1(see figure 4).

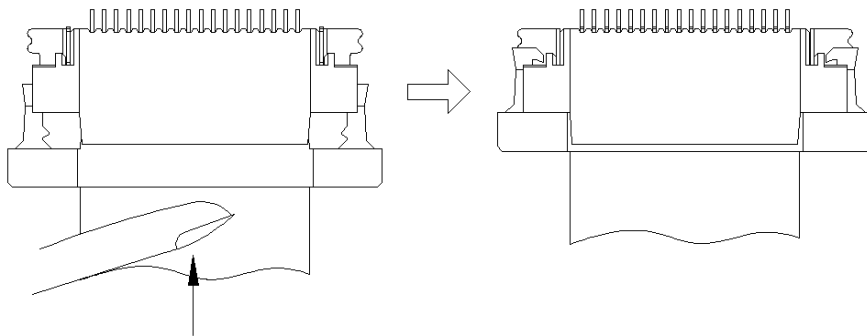

Figure 4.

FPC/FFC Removal.

- 1) Seize the actuator(Lock) to pull out. Use thumb and index finger. (see figure 5).
- 2) Carefully withdraw the FPC/FFC. (see figure 5).

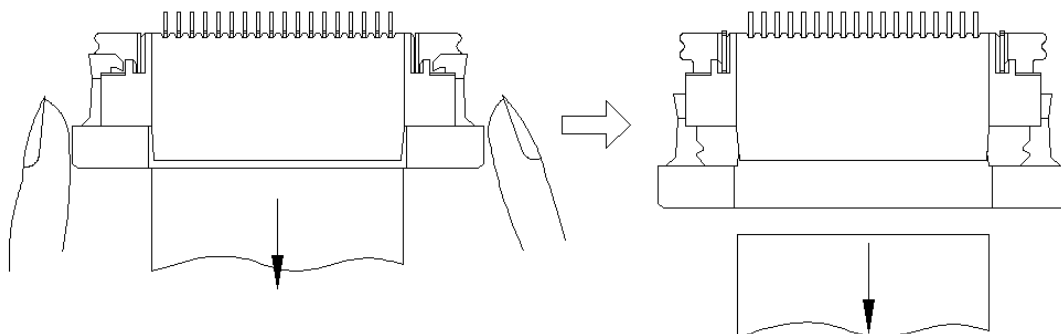

Figure 5.

4. Precautions When Inserting or Withdrawal FPC/FFC

- FPC/FFC to be insertion and withdrawal at an angle of about 15° , and the FPC/FFC should be inserted firmly all the way to the back. (see figure 6).

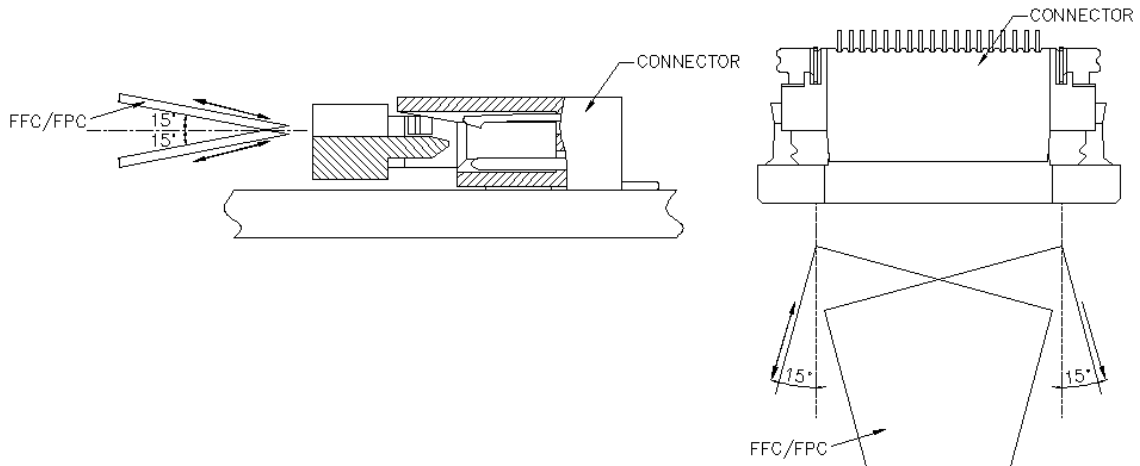

Figure 6.

- If necessary, please fix the FPC/FFC directly on the chassis. Also, please avoid pulling the FPC/FFC vertically or twisting the FPC back and force horizontally while it is inserted in the connector(see figure 7).
- Forming processing is conducted to FPC so as not to load force to connector. (see figure 7).

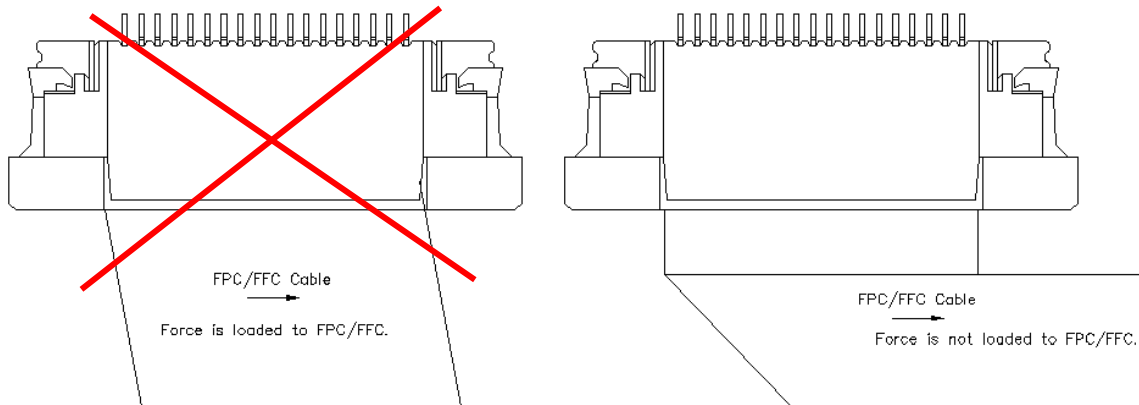

Figure 7.

ENTERY INDUSTRIAL CO., LTD.

RELEASE HISTORY

Rev.	Revisions	Date	Executor	Description
A0	REN120903	Sep-06-2012	KAZ	First Release
A1	REN150401	Apr-01-2015	Juno	MODIFY